

eluma

ALUMINUM FRAME LED PANELS

Company: _____

Contact Name: _____

Address: _____

City, State, Zip: _____

Phone #: _____

Fax #: _____

Email: _____

Request for: Quote Order



Profile Type:

EL001 (Natural Aluminum Finish) EL001S (Stainless Steel Finish)

EL002 (Natural Aluminum Finish) EL002S (Stainless Steel Finish)

Date: _____

PO Number (if applies): _____

Insert Type: (6mm or 1/4")

Glass - Tempered (etching options below)
Glass may contain minor imperfections which are inherent to the mfg process.

Acrylic - Abrasion resistant coating on both sides
Acrylic is abrasion resistant but not scratch proof.

LED Color Temperature:

Warm - Ambient Light (3500K)

Daylight - Natural Light (6500K)

Accent Color Options:

NO

YES _____
List accent color choice

Etching Options: (Glass Inserts Only)

1/4" etched lines @ 1/4" spacing

1/16" etched lines @ 1/4" spacing

custom logo (.jpg or .bmp file required)
ALL etching will be on bottom of glass panel only.

Power Components (1 LF of LED light output = 3W):

QTY: _____ DC-ELT18-CON: 12V DC 18W max. transformer with 6 connector mounting block (Up to 6 LF of LED panel lighting)

QTY: _____ DC-ELT60-CON: 12V DC 60W max. transformer with 6 connector mounting block (Up to 20 LF of LED panel lighting)

Panel Specs: inches mm

Item	Qty	Width	*Depth/Height	Wire Exit (Shelf/ Panel) FB=Front/Bottom BT=Back/Top
1				
2				
3				
4				
5				
6				
7				

Adjustable Shelf/Panel Components: OPTION A

QTY: _____ MAG-TR-1M: 1m (39 3/8") power bar track with 305mm (12") lead with end caps

QTY: _____ MAG-ADP: Magnet Adapter - Connects adjustable shelf to power bar track

QTY: _____ EXT-2M: 2m (79") extension b/w power bar track & transformer

Hardwire Shelf/ Panel Components: OPTION B

QTY: _____ LED-PKT-2M: 2m (79") power lead for direct wiring of panel
(extension required for ALL hardwire applications)

QTY: _____ EXT-2M: 2m(79") extension wire for LED-PKT-2M (optional)

On-Off Switch Components: OPTIONAL

QTY: _____ RDSW-2M-WH: white round rocker switch w/ 2m(79") lead

QTY: _____ RDSW-2M-BL: black round rocker switch w/ 2m (79") lead

QTY: _____ TS2-72: two step on-off touch sensor w/ 1.8m (72") lead
(controls up to 3 transformers)

* subtract 1/2" from shelf depth in adjustable shelf applications for power bar track

* subtract 1/4" from shelf depth in fixed shelf applications

Notes: _____

Ask us about our aluminum frame cabinet doors.

fax your form to: 800-756-9077 Customer support call: 800-756-8077

Technical specifications are subject to change without notice

Adjustable Applications: LED Shelves (OPTION A)

Face Frame LED Shelf Cabinet Application

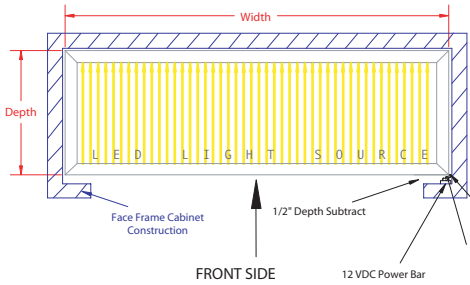

- 1) Power bar to be mounted on right side of the inside on the face frame
- 2) Panel exit wire on front right (LED light source) width rail of panel
- 3) Subtract 1/2" from standard shelf depth for power bar & magnet attachment

Frameless LED Shelf Cabinet Application

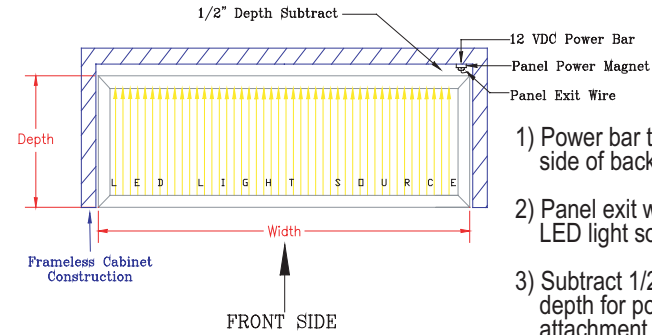

- 1) Power bar to be mounted on right side of back wall of frameless cabinet
- 2) Panel exit wire on back right (opposite LED light source) width rail of panel
- 3) Subtract 1/2" from standard shelf depth for power bar & magnet attachment

Fixed/ Hardwired Applications: LED Panels or Shelves (OPTION B)

Bottom or Front Side Exit Wire for LED Panel or Hardwired Shelf Application

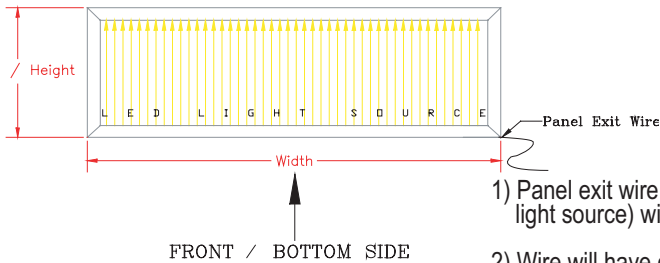

- 1) Panel exit wire on bottom or front right (LED light source) width rail of panel
- 2) Wire will have connector for plug into transformer or into 2m (78 3/4") extension wire
- 3) Subtract 1/4" from standard shelf depth

Top or Back Side Exit Wire for LED Panel or Hardwired Shelf Application

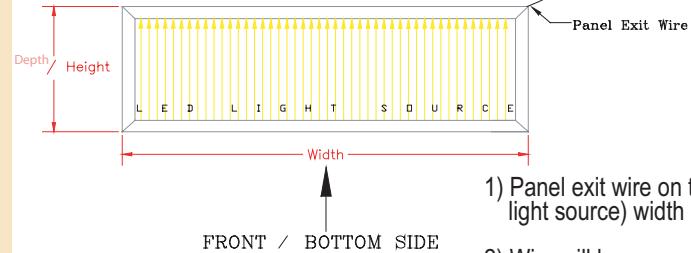

- 1) Panel exit wire on top or back right (LED light source) width rail of panel
- 2) Wire will have connector for plug into transformer or into 2m (78 3/4") extension wire
- 3) Subtract 1/4" from standard shelf depth

Electrical Components

